

# EMG

## PRESSES



PRESSES PNEUMATIQUES  
PNEUMATIC PRESSES  
PNEUMATIK PRESSEN  
PRENSAS NEUMÀTICAS

360 kg → 6 t



	6 PHR	8 PHR	1T	1TGP	3T 4,3T	3TGP 4,3TGP 6T
A	16	20	16	16	14	14
B	35	35	30	30	30	30
C	12	12	15	15	15	15
D	26	28	26	26	30	30
E	-	22	15	15	15	15
F	-	M16	M8	M8	M8	M8
G	8	12	12	12	12	12
H	15,5	21	21	21	21	21
I	10	9	9	9	9	9
J	7,5	9	9	9	9	9
K	160	200	300	300	305	300
L	145	175	200	300	190	295
M	14	20H7	32H7	50	30	50
N	138	19,5	50	50	50	85
O	-	150	265	290	290	400
P	200	230	225	225	225	225
Q	31	55	105	120	147	150
R	250	270	340	425	550	700
S	240	260	250	270	255	300
T	400	450	510	610	-	-
U	640	870	840	955	675	800
V	G.1/4	G.3/8	G.1/2	G.1/2	G.1/2	G.1/2*

\* 6T : G.3/4

### 6PHR - 8PHR

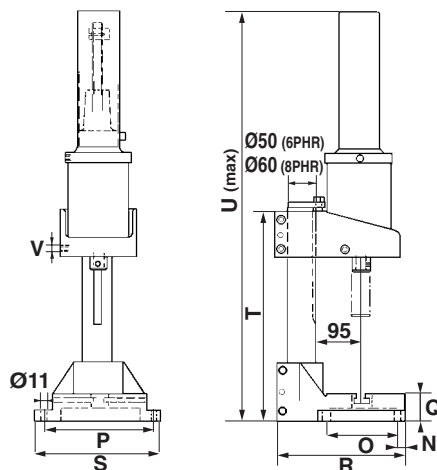

### 1T - 1TGP

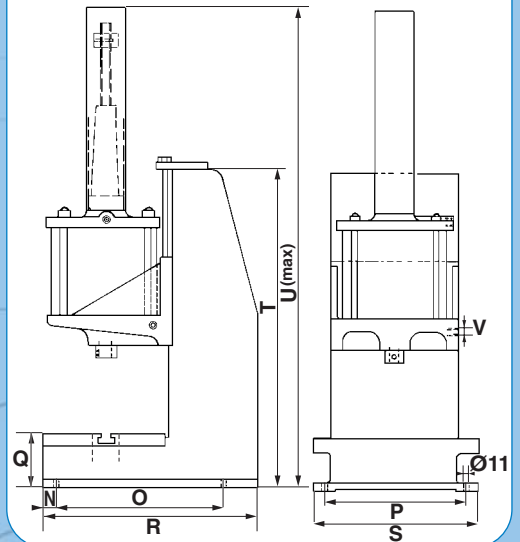

### 3T - 4,3T - 6T 3TGP - 4,3TGP

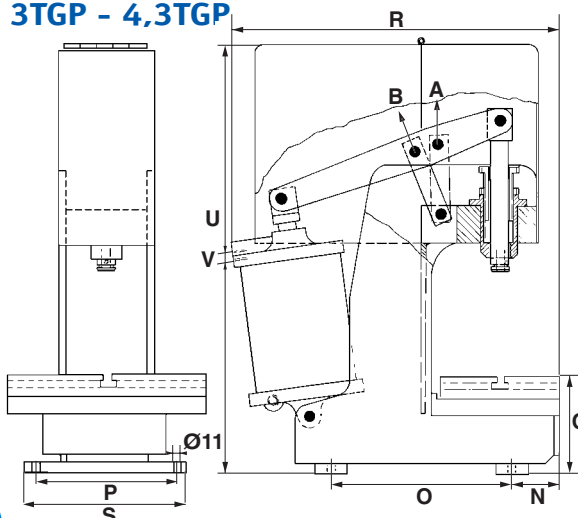

### 6PHR - 8PHR 1T - 1TGP 3T - 3TGP

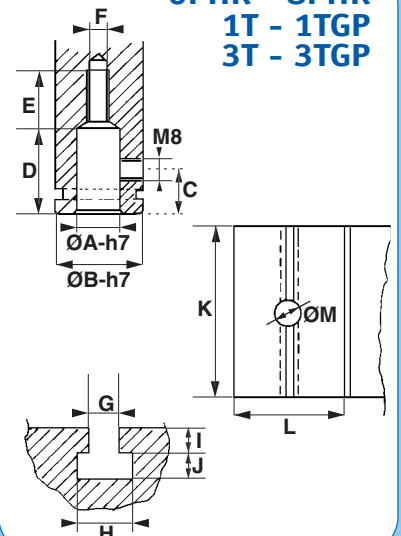

- Le coulisseau est immobilisé en rotation.

- La course est réglable.

Ces modèles à double effet, particulièrement robustes, sont fréquemment utilisés pour des opérations de montages, assemblages, petits cambrages, sertissages divers...

Ces presses offrent toutes les garanties en utilisation normale.



- The slider is locked for rotation.
- Adjustable stroke.

*These double acting models, specially robust, are often used for work involving assembly, connections, small forms, crimping, miscellaneous...*

*These presses offer all guarantees for normal use.*



- Der Stößel ist verdrehgesichert.
- Regelung des Stößelhubes mittels Schraube

*Diese besonders robusten Modelle mit doppelt-wirkendem werden vorrangig für Stranzen, Nieten, Prägen, Montieren, Kleben, Einpressen...*

*Diese Pressen bieten bei normaler Verwendung alle erforderlichen Sicherheitsgarantien.*



- El carro esta immobilizado en rotación

- Arreglo de la carrera por tornillo

*Estos modelos a doble efecto, particularmente robustos, son utilizados para operaciones de montaje, ensamblaje, pequeños doblados, remachar...*

*Estas prensas ofrecen todas las garantías en utilización normal.*



**PRESSES  
PNEUMATIQUES**



**PNEUMATIC  
PRESSES**



**PNEUMATIK  
PRESSEN**



**PRENSAS  
NEUMÁTICAS**

**6PHR**



**8PHR**



**1T**



**1T GP**



**3T  
4,3T**



**3T GP  
4,3T GP  
6T**



						<b>6 PHR</b>	<b>8 PHR</b>	<b>1T</b>	<b>1T GP</b>	<b>3T</b>	<b>4,3T</b>	<b>3T GP</b>	<b>4,3T GP</b>	<b>6 T</b>
Puissance	Power	Leistung	Potencia	kg	360	700	1 000	1 000	A=3000 B=1900	4 300	A=3000 B=1900	4 300	6 000	
Course	Travel	Hub	Carrera	mm	0→50	0→100	0→100	0→100	A=0→54 B=0→69	0→40	A=0→54 B=0→69	0→40	0→50	
Hauteur libre	Clear height	Nutzhöhe	Altura libre	mm	20→250	20→260	140→200	300	A = 180 B = 195	175	A = 295 B = 310	290	290	
Profondeur col de cygne	Swan-neck depth	Ausladung	Profundidad de cuello de cisne	mm	95	95	100	180	110	110	180	180	180	
Poids	Weight	Gewicht	Peso	kg	25	50	125	150	150	150	200	200	230	
Vitesse descente	Lower speed	Stößelgeschwindigkeit	Velocidad de descenso	mm/sec.	150	130	100	100	A = 48 B = 75	36	A = 48 B = 75	36	40	
Consommation d'air	Air consumption	Verbrauch	Consumo de aire	l	1	2,5	3,5	3,5	5,2	5,2	5,2	5,2	9,8	



Synonyme de robustesse, de fiabilité et d'endurance, les presses EMG sont utilisées depuis plus de 40 ans. EMG, c'est aussi :

- Presses manuelles d'établi
- Presses de marquage
- Presses hydrauliques d'atelier
- Presses hydropneumatiques
- Presses mécaniques



*EMG presses, the name for robustness, reliability and endurance, have been used for over 40 years. EMG, is also :*

- *Manual bench presses*
- *Impactor presses*
- *Hydraulic workshop presses*
- *Hydropneumatic presses*
- *Mechanical presses*



*EMG - ein Begriff für Robustheit, Zuverlässigkeit und hohe Standzeit. Die EMG-Pressen werden seit mehr als 40 Jahren erfolgreich produziert. EMG, sind auch :*

- *Manuelle Pressen*
- *Prägepressen*
- *Hydraulische werkstattpressen*
- *Hydropneumatische Pressen*
- *Mechanische Pressen*



Sinonimo de robustez, de fiabilidad y resistencia, las presas EMG se utilizan desde hace mas de 40 años. EMG, es tambien :

- Prensas manuales de banco
- Prensas de marquaje
- Prensas hidraulicas de taller
- Prensas hydroneumaticas
- Prensas mecánicas



LONG S.A.  
Z.I. des Grives  
74150 Marigny-St-Marcel - France  
Tél. +33 (0)4 50 01 11 58  
Fax. +33 (0)4 50 01 14 85  
E-mail : [contact@emgpresses.com](mailto:contact@emgpresses.com)  
[www.emgpresses.com](http://www.emgpresses.com)

